

FB150304NUA2MC

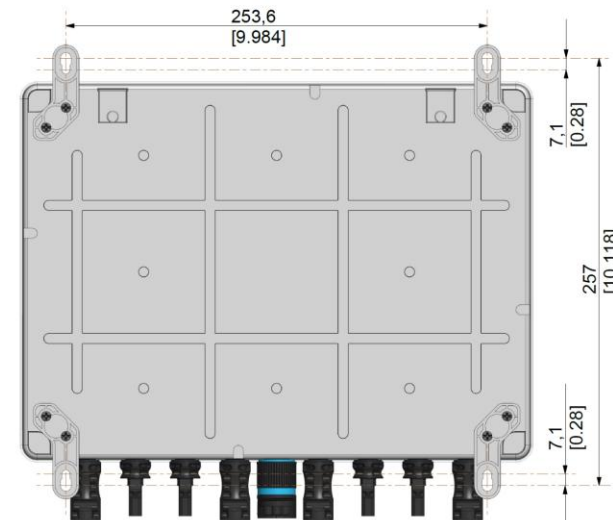

STAFFE PER MONTAGGIO A PARETE

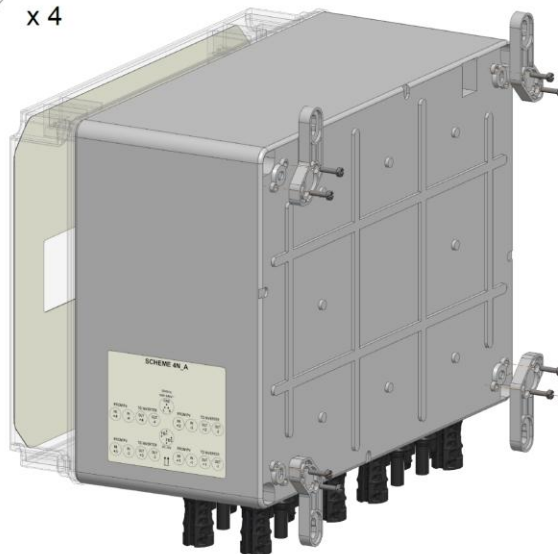
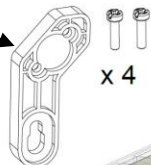

FORI DI FISSAGGIO A PARETE PER STAFFE VERTICALI

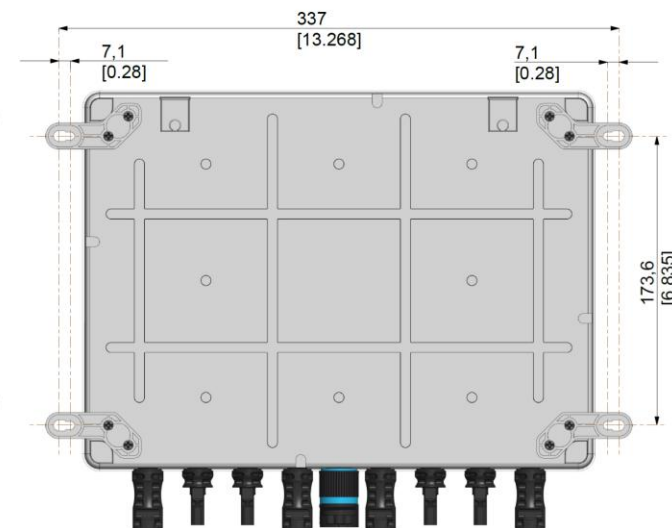
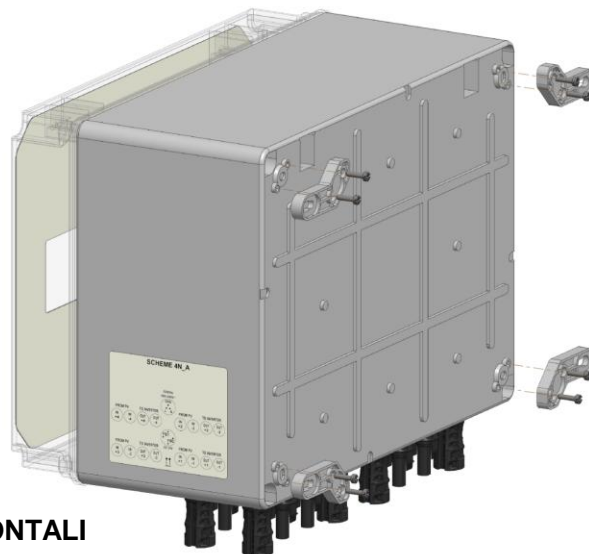
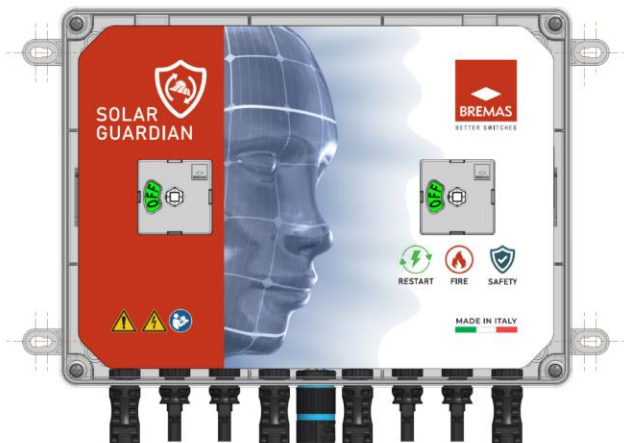

FORI DI FISSAGGIO A PARETE PER STAFFE ORIZZONTALI

Dimension in mm in [inch] Dimensioni in mm in [pollici]

FB150304NUA2MC



Dati tecnici secondo IEC 60947-3				
Tensione nominale d'isolamento	Ui	V	1500	
Tensione nominale di tenuta agli impulsi	Uimp	kV	8	
Corrente termica nominale	Ith	A	50	
Perdita di Potenza per strato a 20 A / 50 A		W	0,2 / 1,25	
Ingressi DC				
Numero di ingressi			4	
Categoria d'impiego			PV1	PV2
Corrente operativa nominale a 1500 V	Ie	A	20	8
Corrente operativa nominale a 1300 V	Ie	A	25	10
Corrente operativa nominale a 1250 V	Ie	A	30	12
Corrente operativa nominale a 1000 V	Ie	A	50	20
Corrente operativa nominale a 800 V	Ie	A	-	30
Corrente operativa nominale a 700 V	Ie	A	-	40
Protezione contro cortocircuito				
Corrente di cortocircuito condizionale nominale		kA	5	
Dimensione massima del fusibile per la protezione da cortocircuito	gPV	A	50	
Corrente nominale sopportata per breve durata (1 s)	Icw	A	780	
Capacità nominale di interruzione di cortocircuito	Icm	kA	1,4	
Terminali				
Tipo di connessione			MC4 connettore a innesto	
Grado di protezione secondo IEC EN 61439-2				
Soluzione in cassetta			IP56	
Condizioni ambientali				
Grado di inquinamento			2	
Temperatura ambiente operativa		°C	-30 ÷ +85	
Temperatura ambiente di stoccaggio		°C	-30 ÷ +85	
Test umidità e calore secondo IEC 60068-2-30			90-100% RH at +55 °C	



SCHEMA 4N_A

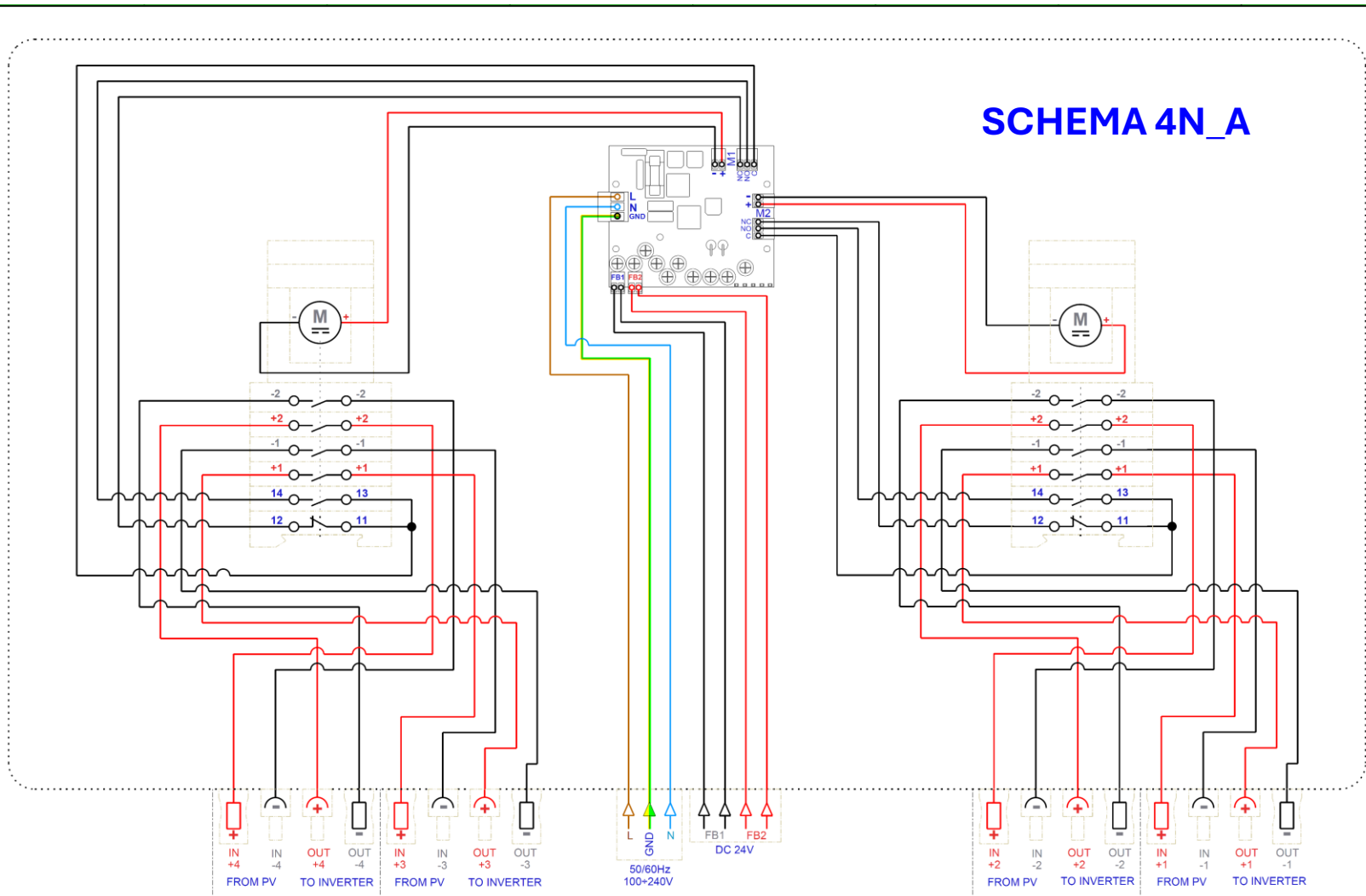

SCHEMA ELETTRICO

NUMERO SERIALE

MINI CONNETTORE A INNESTO IP66/IP68



Number of poles	2 - 3 - 4 poles
Type of contact	Screw / Piercing
Rated current	17.5A AC (IEC) 15A AC (UL / CSA)
Nominal Tension	500V AC 250V AC (use class II) 600V AC / DC (UL / CSA)
Impulse withstand voltage	4kV
Degree of protection (IP6x)	IP66 / IP68 (30m / 3h)
Conductor section rigid / flexible min. – max.	0.5 mm ² – 4.0 mm ² (Screw) 0.5 mm ² – 1.5 mm ² (Piercing)
Cable diameter min. – max. (2)	7.0 mm – 12.0 mm
Connector / gasket materials	PA66 GF UL94 VO / V2 TPE Halogen Free / Silicone Free
Ambient Temperature min. - max.	-40°C / +125°C
Norm	EN61984 UL2238 C22.2 No 182.3

ASSEMBLY ILLUSTRATIONS

Cable	Ø 7.0 – 12.0 mm
Insulator removal (X)	20 mm
Peeling of the conductor (Y)	6 mm

FIG. 1

- Remove the insulation from the cable and conductors according to the specifications indicated.
- Insert the cable through the nut, the grommet and the body of the cable gland.
- Check the correct use of the grommet with respect to the cable to be installed in the connector as indicated in Fig. 1b.

Grommet / Adapter	Cable Ø min. - max.	
	◆	★
	2 - 3 - 4 - 5 poles	2 - 3 - 4 - 5 poles (L)
	9.0 mm – 12.0 mm	9.0 mm – 13.5 mm
	7.0 mm – 9.0 mm	7.0 mm – 9.0 mm
	5.0 mm – 7.0 mm	6.0 mm – 7.0 mm

For cables with a smaller diameter, use the appropriate accessories

FIG. 1b

0.8 Nm (2 - 3 - 4p Screw)
0.2 Nm (5p Screw)
0.1 Nm (2 - 3 - 4p Piercing)

FIG. 2

Fig. 2a

- Insert the individual conductors into the connector terminals, making sure they are correctly positioned (Fig. 2a – example of incorrect installation).
- Turn the cable tightening screws clockwise (max. 0.2 Nm) for the 5 poles, (max. 0.8 Nm) for the 2 - 3 - 4 poles Screw and (max. 0.1 Nm) for Piercing versions.

max. 2.0 Nm

FIG. 3

Fig. 3a

- Join the strain relief to the connector, then turn it clockwise (max. 2.0 Nm).
- Then, insert the grommet into the cable gland (Fig. 3a – in case of a double grommet, make sure to insert the grommet into the cable gland according to the correct orientation: the indicated ring must be visible).
- Make sure the cable gland is installed and screwed correctly onto the connector (Fig. 3b).

24 mm

max. 2.5 Nm

FIG. 4

- Then, join the nut and rotate it clockwise using the quick tightening wrench max. 2.5 Nm. The key will slip when you have reached the optimum torque.
- It is possible to fix the nut also by using common use tools (24 mm – max. 2.5 Nm).

FIG. 5

Fig. 5a

- Make sure the correct orientation of the plug and socket connectors as indicated by the arrow (Fig. 5a).
- Join the pre-wired connectors together, until reaching the limit switch ensuring correct coupling.

max. 1.0 Nm

FIG. 6

Fig. 6a

- Manually clockwise rotate the fixing ring of the plug connector until a firm resistance to rotation is reached.
- Alternatively, rotate the ring clockwise with the use of a tool until the torque is reached (max. 1.0 Nm).
- The socket and plug connector is correctly joined and the IP66/IP68 seal is guaranteed even if you notice a slight slot in correspondence with the fixing ring (Fig. 6a).

FIG. 7

- It is recommended to use adapters for single conductors or for cables with a smaller diameter than what indicated in the TECHNICAL DATA table.
- TPE and Silicone rubber pads available